



cityRev version 3.0

REVENUE MANAGEMENT EFFICIENCY

KEY FEATURES

- ⦿ Complete base registration of Persons and Businesses (e.g. Taxpayers) and Assets (e.g. Properties).
- ⦿ Flexible configuration of different Revenue Types (One application for Taxes, Fees, and other Revenue).
- ⦿ Upload of (new) valuations of Properties.
- ⦿ Powerful Billing and Calculation engine supporting your calculation rules.
- ⦿ Configurable Accounting schema for flexible integration with Government wide Financial systems
- ⦿ High traceability / auditability

The cityRev solution offers a set of features and functions to address the needs of local government authorities responsible for the administration, levy, and collection of revenue. These capabilities are contained within a configurable software application that is maintainable and upgradeable. The solution is specifically designed and built to help local government authorities achieve objectives such as maximizing compliance, improving citizen service, enhancing collection and disbursement capabilities, and providing flexibility to respond quickly to legislative change.

OVERVIEW

cityRev provides out of the box processing and business rules across key business process areas, including Registration of Persons and Assets, Accounting, Payments, Billing, and Collections. This functionality is provided in a modern n-Tier application with a browser-based user interface, and a Service Oriented Architecture (SOA) framework. The solution is flexible, configurable, and upgradeable to provide long term value to customers over the long life of a mission critical revenue management system.

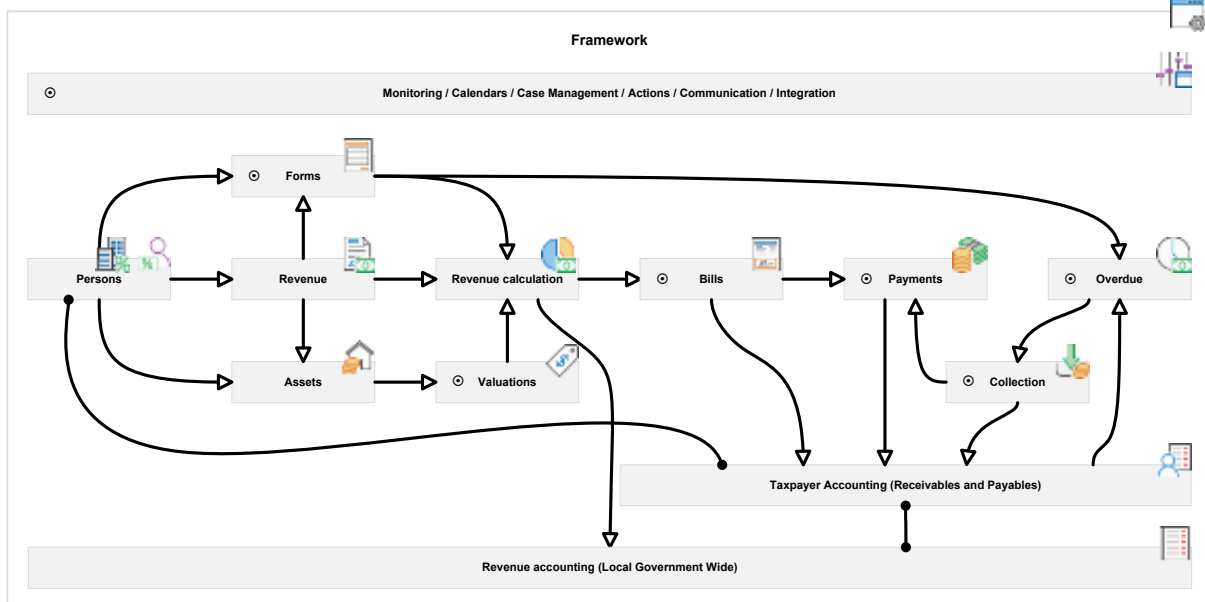

The application includes the following modules:

- ⦿ Foundation framework, Base Registrations, Valuation uploads, Accounting, Billing, Payments, Debt Management, and export of Financial Transactions.

KEY BENEFITS





- ⦿ View of Taxpayers provided with robust and flexible search capabilities.
- ⦿ Collections features to improve compliance and reduce the revenue gap.
- ⦿ Real-time statistics for better control over business processes
- ⦿ Easy to understand by hiding complexity.
- ⦿ Easy to use through offering functions using a clear menu structure and Wizards where possible.

RELATED PRODUCTS AND SERVICES

- ⦿ Hands-on Implementation Services to increase Revenues and improve Services.
 - Analysis and strategy development
 - Improved and modernized business processes
 - Implementation support of cityRev software
 - Improve Taxpayer communication
 - Program and Project Management
- ⦿ Real-time statistics for better control over business processes
- ⦿ Data Warehouse and BI capabilities
- ⦿ Data conversion services

cityRev offers a robust, flexible Person search with an integrated search capability. This includes a complete overview of the Person, assets, relationships, accounts, obligations, and financial information. cityRev provides local revenue authorities a single authoritative source of integrated citizen and asset information, making it easier to respond to citizen inquiries, resolve issues, and complete business processes.

cityRev supports, next to capturing name and address details, also registration of multiple ID-(cards), Phone numbers and E-mail addresses. Setting Communication preferences will allow improvement of Constituent Services.

Registration of a person is supported by a wizard function, taking staff by the hand, guiding them through the registration process, making sure all required data is captured.

REGISTRATION OF PROPERTIES (ASSETS)

Like the Person Registration capabilities, cityRev offers a robust, flexible Property (Asset) search with an integrated search capability. This includes a complete overview of the Asset, related persons, obligations, valuation data (reconstruction value from LVD) and all sorts of financial information. cityRev supports, next to capturing address details (Physical location - Street names / house numbers / Landmarks), also, Postal codes, Geo locations, Electoral areas and communities or any other categorization.

The flexibility of the application caters for adding technical details of an asset when desired. Future changes do not require code change but merely extension of the configuration. Something a trained admin user can do.

Registration of a Property (or any other asset) is supported by a wizard function, taking staff by the hand, guiding them through the registration process, making sure all required data is captured.

Owner and tenant data is kept for historical and statistical purposes.

This way, cityRev provides local revenue authorities a single authoritative source of integrated asset information.

REGISTRATION OF RELEVANT IGF SOURCES

Applicable attributes such as the different property rates that depend on area, property usage and impost are standard elements for the application.

For Business Operating Permits relevant elements e.g., Category of business and Class of business are captured not limiting other.

REGISTRATION OF PERSONS

FLEXIBILITY AND UPGRADEABILITY





- ⦿ Configuration management tools make it easier to apply revision control to cityRev application objects.
- ⦿ Configuration is fully upgradable from previous versions.

elements to be captured for informational purposes of further future use.

REVENUE CALCULATION AND BILLING

Revenue calculation or Taxation is the process where the revenue is being calculated based on the registered data on a contract or based on an ad-hoc situation.

cityRev comes with a wizard that guides you through the taxation process, by helping to 1) select the Revenue Type, Billing groups to process (different billing groups allows for e.g. handling large volumes of data), 2) create the bills (PDF format), outstanding debt and the obligations to pay.

All financial transactions are captured as cityRev behaves as an Accounts Receivable application.

Based on communication preferences the bill can be either be printed or sent via text message (e-Billing). Usage of bill templates simplifies creation of the bill with your specific data (like contact information, logo, and signature).

PAYMENTS

All types of payments (Partial, full, advance) are fully supported allowing a complete view on the financial position of the Taxpayer. The application supports Cash, Mobile and Bank payments with rules for automated debt reconciliation.

COLLECTION

When a Taxpayer does not promptly settle the outstanding debt, cityRev supports sending out Reminders and Warrants and supports Enforced Collection Cases.

FINANCIAL TRANSACTIONS & AUDIT TRAILS ON RELEVANT DATA

The cityRev application creates financial transactions during 1) Tax calculation, 2) Billing, 3) Calculation of Overdue (Penalty & Interest), 4) Cash and Bank Payments (incoming / out-payments) taxpayer related and 5) Waivers and Write-off.

The Financial Transactions are kept on Taxpayer Account level, giving an immediate overview of the Financial position (debt) of the Taxpayer.

The cityRev application comes with a set of Financial Control functions which will allow for setting up the specific behaviors needed to interface (not integrate) with external revenue applications (e.g. General Ledger).





LOCALIZATION

- True multi-lingual capabilities, not only in the User Interface, but also with client communication
- Easy translation capabilities for other languages that need to be supported.
- Supports left-to-right and right-to-left User Interface.
- Multi-currency, where currency even can be labor or goods.
- Supports different calendars (e.g. Gregorian and Ethiopian)

Each Local Government can use (when applicable) its own Chart of Accounts, or the Chart of Accounts prescribed by (Regional or National Government are equal).

cityRev was designed with traceability and auditability in mind and therefore, 2 basic rules are applied:

1. Every manual change to the data in the system which directly (e.g. impost) or indirectly (e.g. zone) has a financial impact, is logged. The logging contains the old value, the new value, date and time of change and the person who made the change. This data cannot be changed.
2. Every activity in the system, either by hand or by the software itself, with a direct financial impact, automatically creates financial transactions (FTs) for the general ledger and account transactions (ATs) for the Account Receivable sub-ledger. Based on the configuration settings, the system assures that the proper account numbers will be used. It is impossible to remove these FTs from the system. When mistakes are made, it is of course possible to reverse an incorrect bill, but this will result in another set of FTs. These reversal entries could be triggers for extra auditing activities!

INTERFACING

Interfacing is done using an (a-)synchronous interface. There are 2 types of interface streams supported:

1. Inbound
2. Outbound

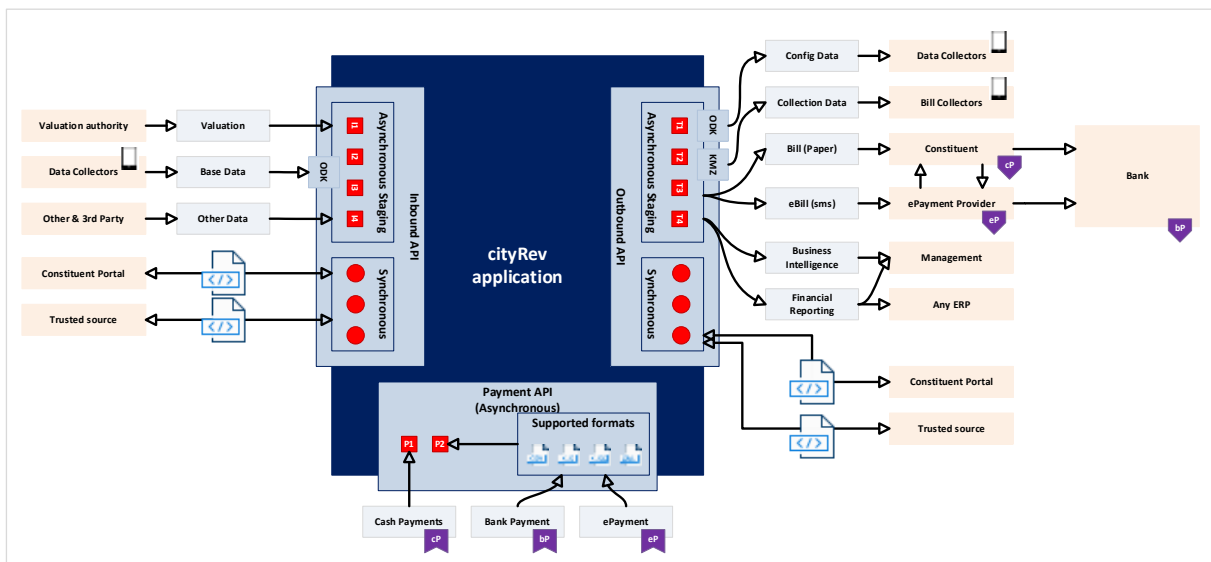

Using Inbound

cityRev can only process data uploaded in records in specific and fit for purpose staging tables. The mechanism is always the same: Per specific staging table, the data needs to be uploaded into the staging table(s). When the data is in the staging table(s), cityRev processes the data.





Using Outbound

cityRev can create data in outbound staging tables. When this data will be used other systems, that data can be extracted from staging table(s).

Export functionality can be used to extract e.g. Financial data on Detail level or on an Aggregated level. Distribution codes will also allow for partial extraction of the data.

Ledger ID	Description	Type	Debit	Credit	Distribution Code
10100	Cash Register	Cash Payment	66.168,62		
10200	Bank Account	Bank Payments	47.952,22		
10200	Bank Account	ePayments	873.589,87		
13000	A/R Taxpayers	Billing	3.289.842,40		
13000	A/R Taxpayers	Cash Payment		66.168,62	
13000	A/R Taxpayers	Bank Payments		47.952,22	
13000	A/R Taxpayers	ePayments		873.589,87	
28000	To be billed	Fiscal Adjustment	3.460.624,40		
28000	To be billed	Billing		3.289.842,40	
80110	Revenue Property Tax - Residential (Private)	Fiscal Adjustment		1.898.635,79	1412022
80120	Revenue Property Tax - Licenced Premises (Private)	Fiscal Adjustment		1.029.382,63	1412022
80130	Revenue Property Tax - Commercial (Private)	Fiscal Adjustment		154.593,67	1412022
80140	Revenue Property Tax - Mixed Use	Fiscal Adjustment		75.987,22	1412022
80150	Revenue Property Tax - Commercial	Fiscal Adjustment		79.568,89	1412022
80210	Business Operating Permits - Other	Fiscal Adjustment		37.820,98	1422000
80220	Business Operating Permits - Herbalists	Fiscal Adjustment		83.562,49	1422002
80230	Business Operating Permits - Liquor	Fiscal Adjustment		36.742,72	1422007
80310	Building Permits	Fiscal Adjustment		46.032,56	1412007
80910	Other	Fiscal Adjustment		18.297,45	1419999
			7.738.177,51	7.738.177,51	

Alternatively, Financial Data can be extracted (ETL) to be used in a data warehouse.

TRUE MULTI-LINGUAL

cityRev is a true multi-lingual application. Additional languages can be added quickly. The user interface can be used in the user's preferred language and the bills to taxpayers in their preferred language(s) (if that translation is part of the setup).

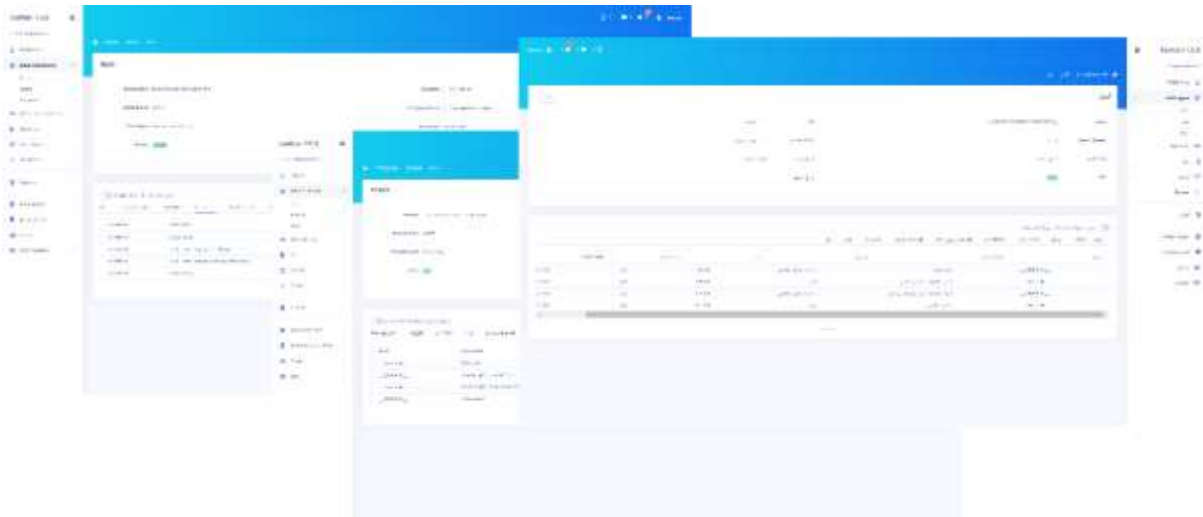

CONTACT US

For more information about cityRev, please send an email to info@allgovmatters.com

Copyright © 2015-2023, All Government Matters B.V., All rights reserved.

This document is provided for information purposes only and the contents hereof are subject to change without notice. This document is not warranted to be error free, nor subject to any other warranties or conditions, whether expressed orally or implied in law, including implied warranties and conditions of merchantability or fitness for a particular purpose. We specifically disclaim any liability with respect to this document and no contractual obligations are formed either directly or indirectly by this document. This document may not be reproduced or transmitted in any form or by any means, electronic or mechanical, for any purpose, without our prior written permission.

